

MANUAL

MOUNTING – DISMOUNTING

ASSEMBLING – DISASSEMBLING
INSTRUCTION

TECHNICAL
INFORMATION

ET-USO
ET-USI



DSI SERVICE – TEAM

Sales Department DSI Hamm

Sabine Groneberg
DSI Hamm Germany, Austria, Switzerland
Phone: +49 (0) 23 85 772 212
E-Mail: groneberg@dsi-group.net

Sandra Leszynsky
Western Europe and UK, USA, Australia, Asia
Phone: +49 (0) 23 85 772 214
E-Mail: leszynsky@dsi-group.net

Katrin Poth
France, Spain, Portugal
Phone: +49 (0) 23 85 772 215
E-Mail: poth@dsi-group.net

Iryna Matyak
Eastern Europe
Phone: +49 (0) 23 85 772 216
E-Mail: matyak@dsi-group.net

Sales Department DSI International

CL2
Joost Samyn
Sales Representative
Western Europe
Molenbergstraat 15
1700 Dilbeek
Belgium
Phone: +32 24 52 70 55
Mobil: +32 49 134 39 00
E-Mail: samyn@dsi-group.net

DSI UK
Jeff Garrity
Service Centre
c/o Pegler Yorkshire
ST Catherine's Avenue
Doncaster, South Yorkshire
DN4 8DF
United Kingdom
Phone: +44 13 02 560 190
Mobil: +44 78 02 346 664
E-Mail: garrity@dsi-group.net

Keg Service
Tadeusz Gonciarczyk
Sales Representative
Eastern Europe
UL. Walowa 3
51-523 Wroclaw
Poland
Phone: +48 71 34 66 632
Mobil: +48 50 51 54 152
E-Mail: biuro@keg-service.pl

OJA
Olaf Jakob
Sales Representative
Germany, Austria, Switzerland
Wortmannsweg 14
44149 Dortmund
Germany
Phone: +49 (0) 231 22 50 740
Fax: +49 (0) 231 22 50 741
E-Mail: o.j.a@t-online.de

QUALITY AND SAFETY



Dear customer,

please study this manual thoroughly. Incorrect assembly or disassembly may damage the fitting and can cause harm to product or person.

Specialised sealing systems made of high-grade materials are in daily utilisation with all our types of extractor tubes. Due to continuous improvement of our technology we are able to equip all D-type and S-type systems with a five-year warranty.

LIST OF CONTENTS

1. Mounting Instruction
2. Dismounting Instruction
3. Disassembling Instruction
4. Assembling Instruction
5. Tool List
6. Technical Information

MOUNTING INSTRUCTION

EXTRACTOR TUBE ET-USO / ET-USI

1. Mounting Instruction

ET-USO



ET-USI



MOUNTING INSTRUCTION

EXTRACTOR TUBE ET-USO / ET-USI

Fig. 01



1. Moisten the extractor tube with water.

Fig. 02



2. Check whether the keg neck is clean. Clean the keg neck from any contaminations.

Fig. 03



3. Check whether the sealing ring is not damaged and is positioned correctly.

3.1 ET-USO

Tighten the support ring directly to the o-ring.

MOUNTING INSTRUCTION

EXTRACTOR TUBE ET-USO / ET-USI

Fig. 04



4. Check the correct locking of the base plate and the rail shoring of the safety latch. Insert the extractor tube straight.

Fig. 05



5. Push in the extractor tube by hand. The safety latch will recess and click back after it has passed the keg neck.

Fig. 06



6. Tighten the extractor tube (rotate it clockwise) e.g. with the DSI screw-in/screw-out tool and torque-wrench.

ET-USI: The mounting torque (continuous) must be 80 +5 Nm.

ET-USO: The mounting torque (continuous) must be 65 +5 Nm.

MOUNTING INSTRUCTION

EXTRACTOR TUBE ET-USO / ET-USI

Fig. 07



7. Remove the screw-in/screw-out tool. The keg is ready for use now.

DISMOUNTING INSTRUCTION

EXTRACTOR TUBE ET-USO / ET-USI

2. Dismounting Instruction

ET-USO



ET-USI



DISMOUNTING INSTRUCTION

EXTRACTOR TUBE ET-USO / ET-USI

Fig. 08



1. Decompress the keg, e.g. by means of the DSI decompression and removal tool.

Fig. 09



2. Unscrew the extractor tube (rotate it counter-clockwise) with the DSI screw-in/screw-out tool.

Fig. 10



3. Connect the removal tool like a normal dispense head and press down the handle till it clicks. The safety latch will recess.

DISMOUNTING INSTRUCTION

EXTRACTOR TUBE ET-USO / ET-USI

Fig. 11



4. Take out the extractor tube and disconnect the removal tool.

DISASSEMBLING INSTRUCTION

EXTRACTOR TUBE ET-USO / ET-USI

3. Disassembling Instruction

ET-USO



ET-USI



DISASSEMBLING INSTRUCTION

EXTRACTOR TUBE ET-USO / ET-USI

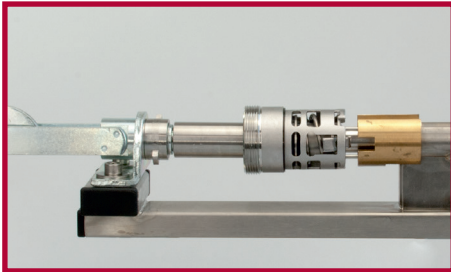

1. Put the extractor tube in the tool. Make sure that the three pins of the tool fit into the three holes in the bottom of the extractor tube plate.

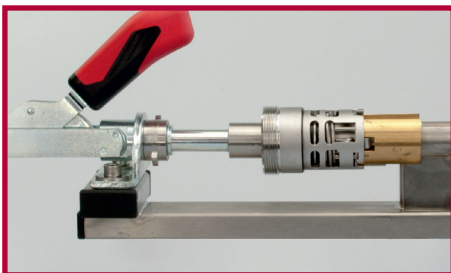

2. Pull the handle forward to compress the spring. Push the safety latch slightly inwards. Pull the body downwards and turn it anticlockwise until it is unlocked.

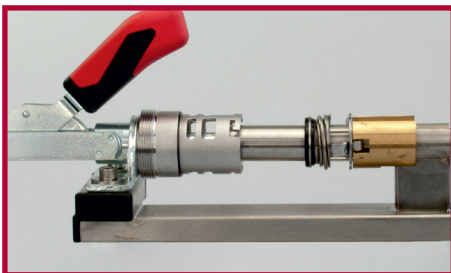

3. Move the body upwards and connect it to the tool by turning the body.

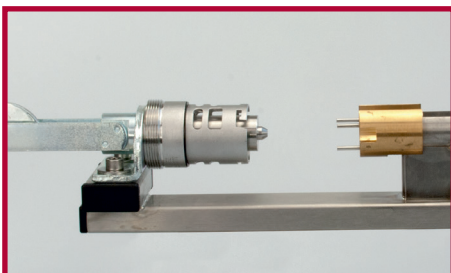

4. Push the handle backward. Take the subassy out. Take the body off.

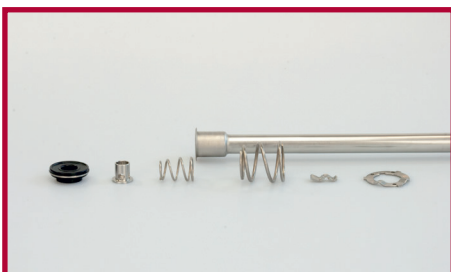

5. Take off the remaining parts. The extractor tube is disassembled.

ASSEMBLING INSTRUCTION

EXTRACTOR TUBE ET-USO / ET-USI

4. Assembling Instruction

ET-USO



ET-USI



ASSEMBLING INSTRUCTION

EXTRACTOR TUBE ET-USO / ET-USI

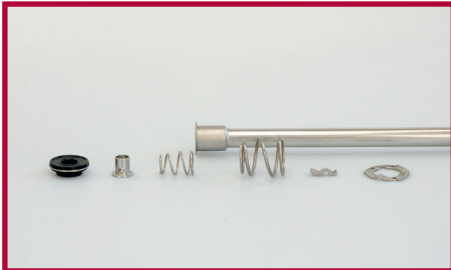

1. Replace the sealing ring on the body and the main seal. Assemble all parts at the tubing.

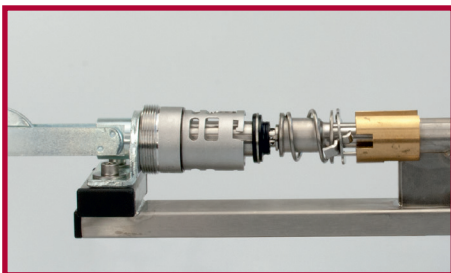

2. Connect the body to the assembling tool. Put the subassy in the tool. Make sure that the three pins of the tool fit into the three holes in the bottom of the extractor tube plate. Push the safety latch slightly inwards.

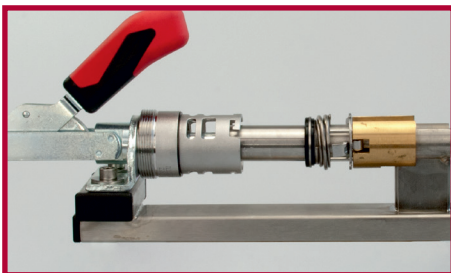

3. Pull the handle forward to compress the spring.

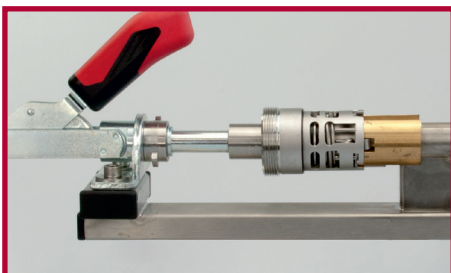

4. Pull the body downwards and turn it clockwise until it is locked to the extractor tube plate. Make sure that the safety latch sticks through the big opening in the body.

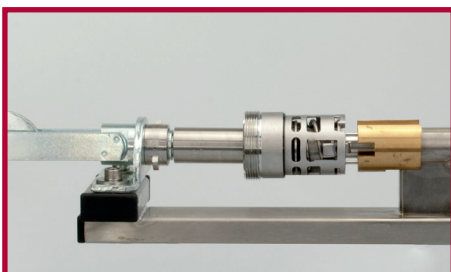

5. Push the handle backward in order to tension the spring and take out the extractor tube. Please check the correct positions of the seals and the safety latch.

TOOLS

EXTRACTOR TUBE ET-USO / ET-USI

5. Tool List

ET-USO



ET-USI



TOOLS

EXTRACTOR TUBE ET-USO / ET-USI



1. Removal- and decompression tool:
part number: 027985.1



2. Screw-in/screw-out tool:
part number: 027981.8



3. Assembling/disassembling tool:
part number 910464

TECHNICAL INFORMATION

EXTRACTOR TUBE ET-USO / ET-USI

6. Technical Information

ET-USO



ET-USI



TECHNICAL INFORMATION

EXTRACTOR TUBE ET-USO

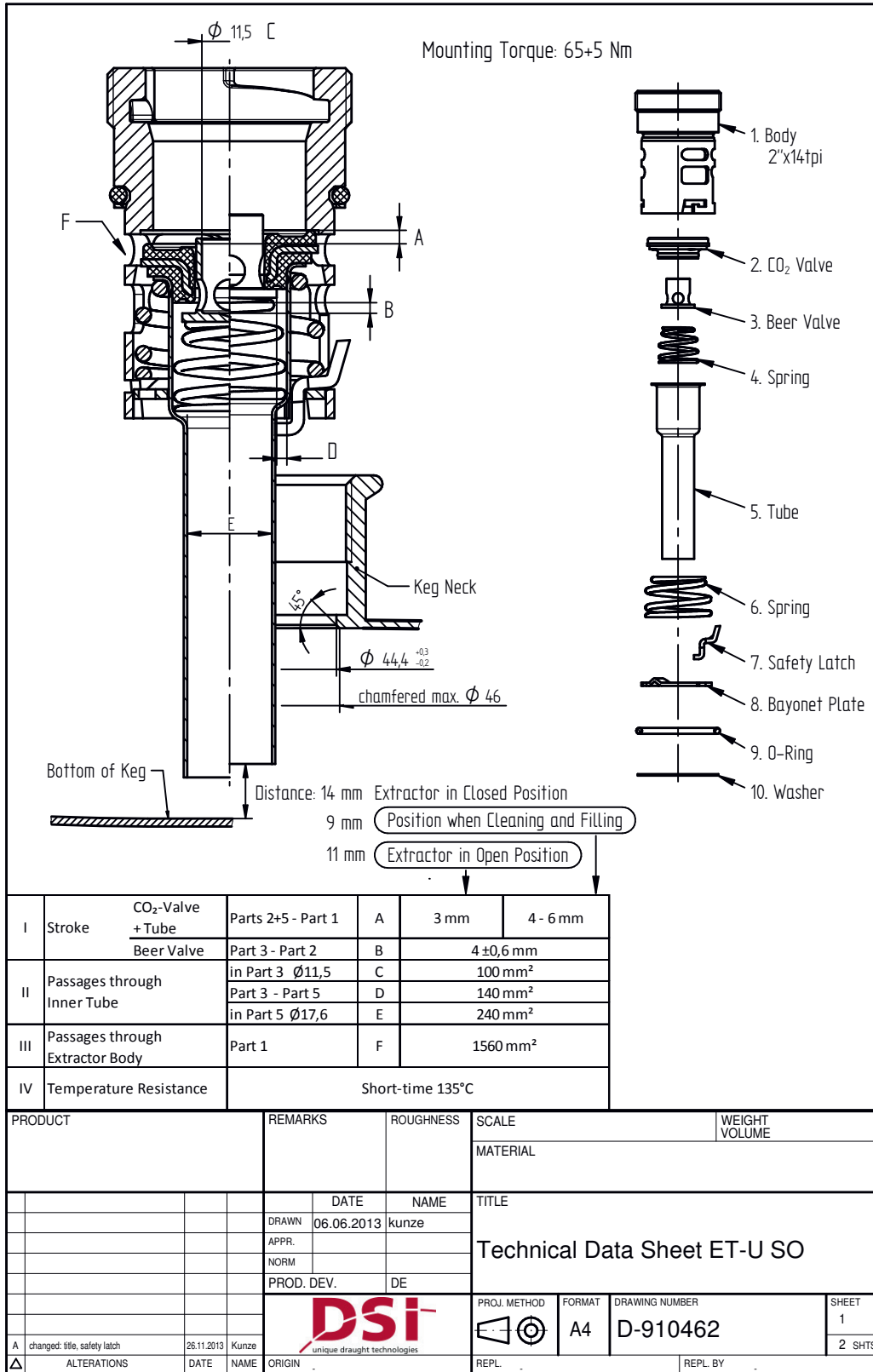

This drawing is the property of Dispense Systems International. The information is confidential and should not be copied for any other purpose without the prior written permission of DSI Getränkeautomaten GmbH. If in doubt, please ask. Samples are required after each revision.

TECHNICAL INFORMATION

EXTRACTOR TUBE ET-USI

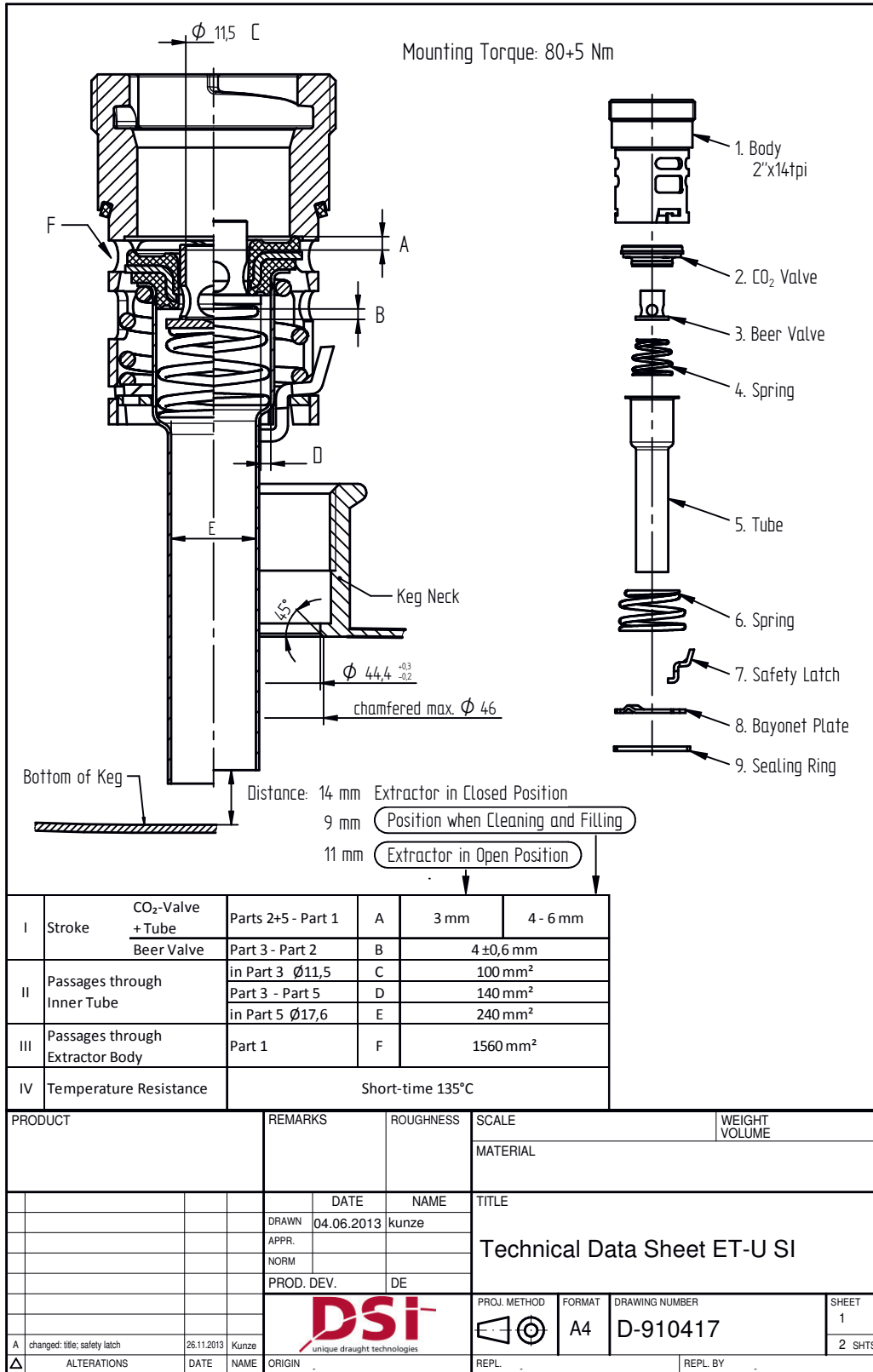

This drawing is the property of Dispense Systems International. The information is confidential and should not be copied for any other purpose without the prior written permission of DSI Getränkearmaturen GmbH. If in doubt, please ask. Samples are required after each revision.

CONNECTION

EXTRACTOR TUBE ET-USO / ET-USI

6. Connection

ET-USO



ET-USI



CONNECTION

EXTRACTOR TUBE ET-USO

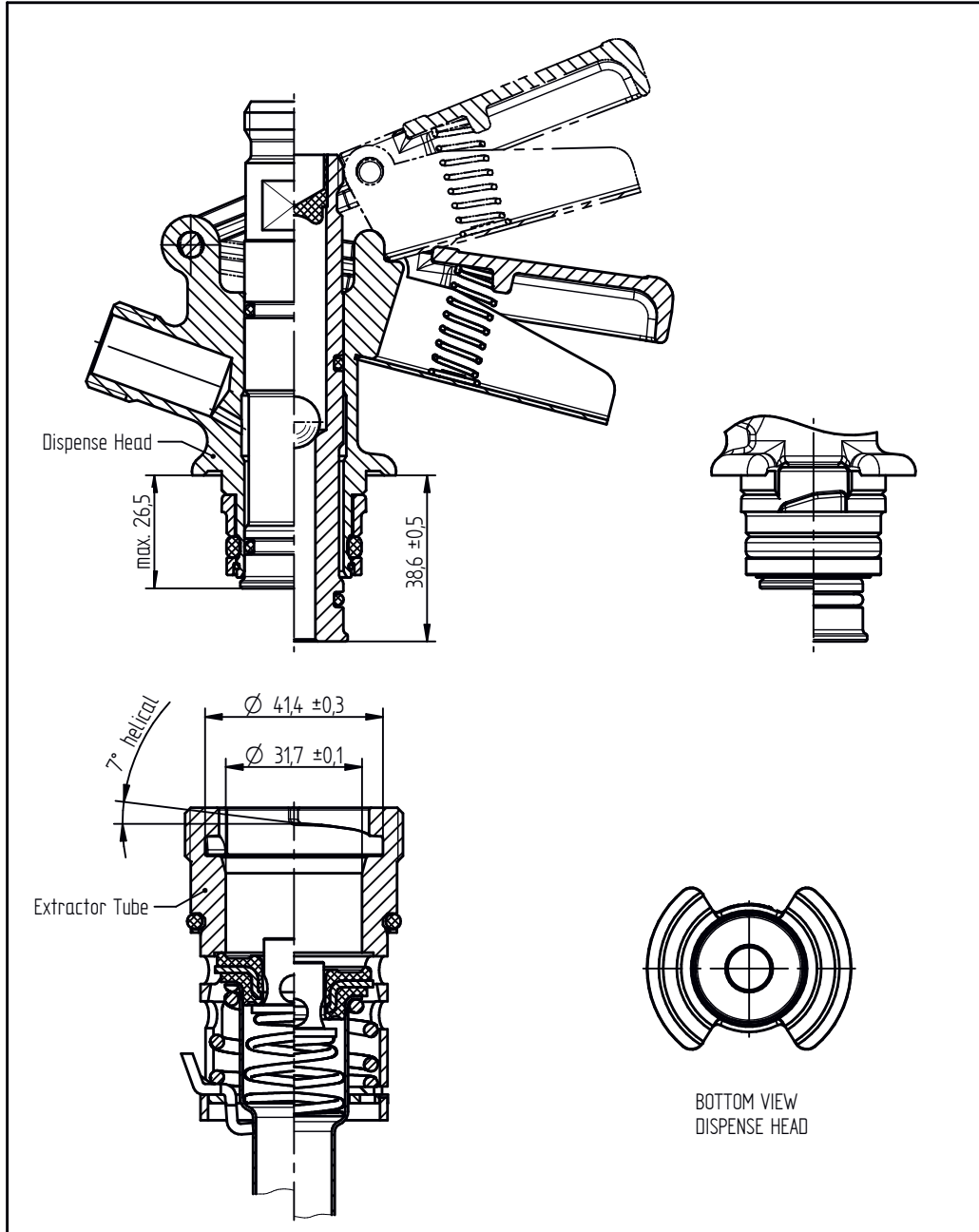

DSI Getränkearmaturen GmbH.
 If in doubt, please ask.
 Samples are required after each revision.

This drawing is the property of Dispense Systems International.
 The information is confidential and should not be copied for
 any other purpose without the prior written permission of

PRODUCT		REMARKS		ROUGHNESS	SCALE	WEIGHT VOLUME	
					MATERIAL		
		DATE	NAME	TITLE			
		DRAWN	17.01.2014	U-Type Connection System SO			
		APPR.					
		NORM					
		PROD. DEV.	DE				
				PROJ. METHOD	FORMAT	DRAWING NUMBER	SHEET
				REPL.	REPL. BY	A4	D-910494
ALTERATIONS		DATE	NAME	ORIGIN			
					2 SHTS.		

CONNECTION EXTRACTOR TUBE ET-USI

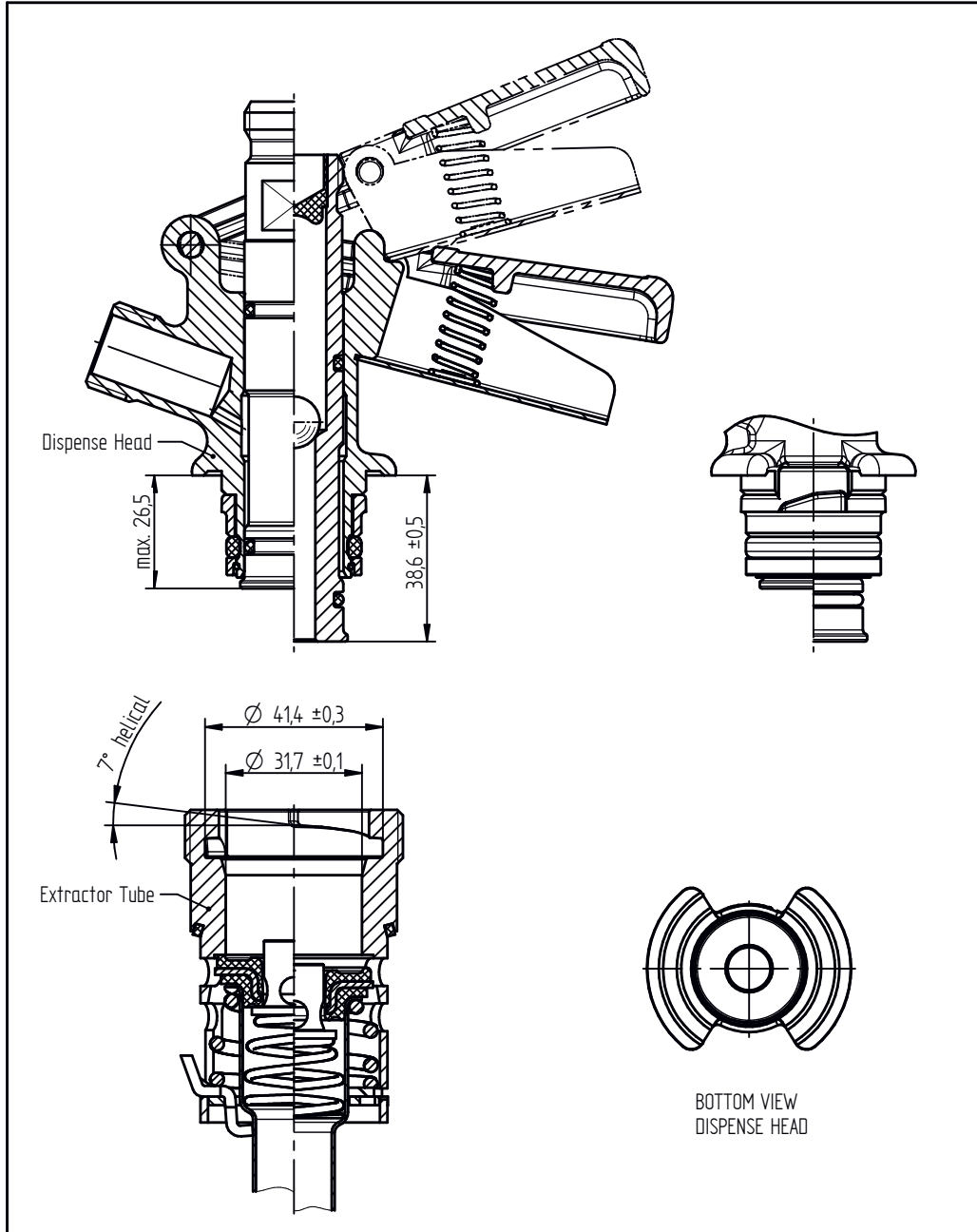

This drawing is the property of Dispense Systems International.
 The information is confidential and should not be copied for
 any other purpose without the prior written permission of
 DSI Getränkeanlagen GmbH.
 If in doubt, please ask.
 Samples are required after each revision.

PRODUCT		REMARKS		ROUGHNESS	SCALE	WEIGHT VOLUME	
					MATERIAL		
			DATE	NAME	TITLE		
			DRAWN	23.01.2014	U-Type Connection System SI		
			APPR.				
			NORM				
			PROD. DEV.	DE			
				PROJ. METHOD	FORMAT	DRAWING NUMBER	SHEET
				REPL.		A4	D-910495
ALTERATIONS		DATE	NAME	ORIGIN	REPL. BY		2 SHTS.



Germany

DSI Getränkearmaturen GmbH
Oberster Kamp 20
59069 Hamm

Phone: +49(0)2385 772 100

Fax: +49(0)2385 772 249

sales@dsi-group.net

www.dispensegroup.com



USA

Taprite
3248 Northwestern Drive
San Antonio, Texas 78238

Phone: +1(210)523 0800

Fax: +1(210)520 3035

sales@taprite.com

www.taprite.com



United Kingdom

DSI Service Centre U.K.
c/o Pegler Yorkshire
ST Catherine's Avenue
Doncaster, South Yorkshire, DN4 8DF

Phone: +44(0)1302 560 190

Fax: +44(0)1302 767 608

sales-uk@dsi-group.net

